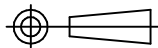

- Notes:**
1. With CCW rotation viewed from brush end, a positive voltage shall be generated on black lead with respect to white lead.
 2. This tach replaces TG 2168. However individual components (armature, stator, brush ring) are not interchangeable.
 3. All dimensions in mm (inch).

Part No.	Winding	Voltage Const. (V/krpm)
M35000-400	" A "	19
M35000-401	" B "	57
M35000-402	" C "	38
M35000-403	" D "	47
M35000-404	" E "	3
M35000-405	" F "	30

				Tolerances. X.X = ± 0.3 mm X.XX = ± 0.1 mm Ang. Dim. = ± 1°		Scale : 1 : 1 	Weight :
				Date 9/6/05		Name POB	
				Drawn App'd		Material : Remove all burrs and sharp corners	
Issue	ECO. No.	Date	Name	App'd	Norm	Tach Ass'y TGF 2030-147 X	
boby servo-electronic ag						M35000-40X	
						Sheet 1 of 1	